



Ice Cube

CB 1265A



Self-contained ice maker - Sprayer system Daily production up to 134 kg

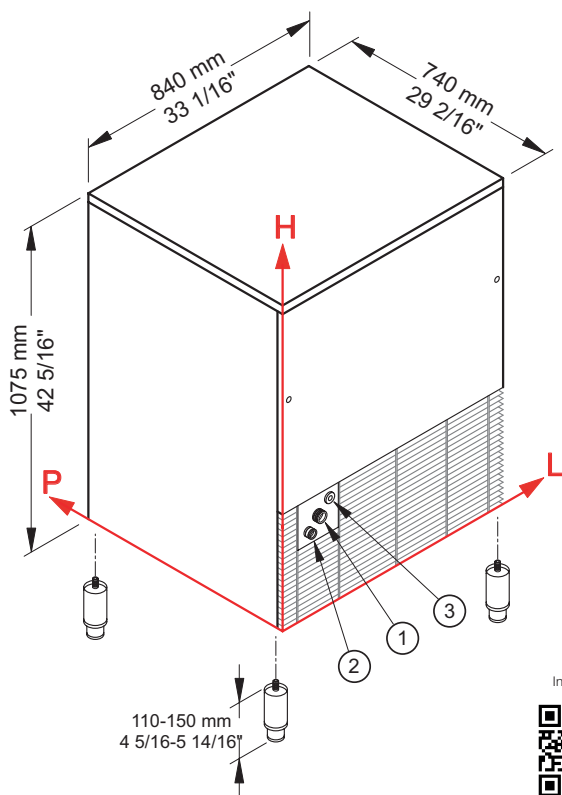

► Working conditions

- Location: **Indoor**

	Min	Max
Ambient temperature	+10° C / +50° F	+43° C / 110° F
Water temperature	+3° C / +37° F	+32° C / +90° F
Voltage	-10%	+10%
Water inlet pressure	1bar (14 psi)	6bar (84 psi)

► Performances

Air temperature	Water temperature	Water temperature					
		7° C	45° F	15° C	60° F	21° C	70° F
10° C	134 kg						
50° F	295 lbs						
21° C			130 kg				
70° F			287 lbs				
32° C					106 kg		
90° F						234 lbs	

► Connections

All measures are referred to the rear bottom-left corner (L-H-Ø)

- ① Water in.: 141 mm / 5 9/16" - 290 mm / 11 7/16" - 3/4" ② Water out.: 79 mm / 3 2/16" - 245 mm / 9 10/16" - 24 mm / 15/16"
- ③ Electrical connections: 186 mm / 7 5/16" - 326 mm / 12 13/16"

► Technical information

Production in 24h	130 kg / 287 lbs
Store capacity, up to	65 kg / 143 lbs
Cooling system	A
Kind of cube	D-13g
Refrigerant	R452A
Standard voltage	220-240 V ~ 50 Hz
Average power consumption	1050 W
Fuse	☒
Finish	AISI 304 stainless steel, scotch brite

Water consumption	A: 2,8 l/kg - 33,5 gal/100 lbs
	W: 15,3 l/kg - 183,3 gal/100 lbs
Sizes (L-P-H mm)	840 - 740 - 1075
(L-P-H in)	33 1/16 - 29 2/16 - 42 5/16
Sizes with pack (L-P-H mm)	880 - 785 - 1245
(L-P-H in)	34 10/16 - 30 14/16 - 49
Net weight	113 kg / 249 lbs
Gross weight	133 kg / 293 lbs

All the technical information need to be considered at the following conditions:

- Standard Cube (18 g)
- Ambient temperature +21° C
- Water temperature +15° C
- Average power consumption at +43° C (standard voltage)

Models and specifications are subject to change without notice

Rev. 04 - Issued September 2019



Bim + Data download

